



Container Specification

Contents

page

Introduction 4

General Information 5

General Purpose Container  **20'** 6
40' 8





**High Cube
General Purpose Container**  **40'** 10

**High Cube
General Purpose Container**  **45'** 12

Hardtop Container  **20'** 14
40' 17

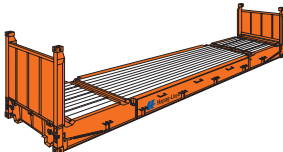
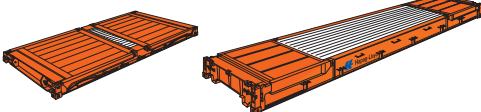
**High Cube
Hardtop Container**  **40'** 20

Open Top Container  **20'** 23
40' 26

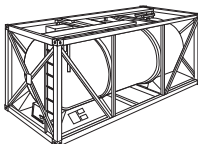
Flat		20'	29
High Cube Flat		40'	31
Platform		20'	33
		40'	33
Ventilated Container		20'	35
Refrigerated Container		20'	37
High Cube Refrigerated Container		40'	40
Tank Container		20'	44
Electric Plugs on Refrigerated Containers			45
Essential Conversion Factors			46
Container Size Type Codes			47

Introduction

Hapag-Lloyd offer to their customers 6 basic types in 20' and 40' versions. With this wide range of standard and special containers we can provide you with the most suitable container for every product.

This booklet gives technical data on all of the Hapag-Lloyd container fleet, such as

- dimensions
- weights
- design features

All values listed in the tables are given in metric. Ft and lbs values are for easy reference only.

All details listed are nominal figures. Apart from the tolerances given on internal dimensions on page 5 the tare weight can vary $\pm 2\%$.

In addition to the Hapag-Lloyd container fleet, we can employ a wide range of leased and partner carrier line equipment.

This booklet only lists technical data. If you are looking for further advice or your special requirements are not yet satisfied, we are more than happy to assist you. Please call your nearest Hapag-Lloyd office or agent and let our experience work for you.

For more product or company information, please visit our web site, which is frequently updated at.

www.hapag-lloyd.com

General Information

Internal Dimensions

The internal dimensions and door openings of all Hapag-Lloyd containers exceed the below given ISO dimensions. However, the dimensions mentioned on the following pages are nominal figures. Because of production tolerances a difference in measurement is possible:

Tolerances	Length	Width	Height
Maximum Difference	10 mm 3/8"	10 mm 3/8"	10 mm 3/8"

Maximum Gross Weights

20' containers:

32500 kg (71650 lbs) valid for most Hapag-Lloyd 20' containers; exceeds ISO minimum standards (ISO 668).

40' containers:

Up to 34 000 kg (74 959 lbs).

Weight Limits for road and rail transport

For individually valid limits contact your local Hapag-Lloyd office.

Floor Loads

A container floor is capable of carrying a fork-lift truck with a maximum axle load of 5 460 kg (12 040 lbs), if the contact area per wheel is at least 142 cm² (22 sq.in) (ISO 1496/1).

Concentrated Loads

Concentrated loads are loads, that are not distributed over the full length of floor, when stowing heavy cargo in containers other than flats or platforms due care has to be taken that concentrated loads will not exceed the strength of the bottom construction of the container.

The maximum spreaded load should not exceed

- for 20' containers 4 ts per running meter in length (3'3³/₈" still higher on request
- for 40' containers 3 ts per running meter in length
- load must not exceed over max. payload

Gooseneck Tunnel on 40' Containers

All Hapag-Lloyd 40' containers are fitted with a Gooseneck tunnel to enable the transport on Gooseneck chassis.

Timber Treatment

Exposed timber is treated according to Australian, Chinese and American requirements.

Container Markings

For easy identification Hapag-Lloyd containers are marked with HLCU- or HLXU- prefix either. Containers built in 1997 or thereafter do also show the ISO Size Type Code. For further information please see page 47.

External and Minimum Internal Dimensions (according ISO)

The following table gives the overall dimensions as standardized in ISO 668 and the minimum internal dimensions and door openings for General Purpose Containers as standardized in ISO 1496-1.

Dimensions	Length			Width	Height	
	20'	40'	45'	8'	8'6"	9'6"
Dimensions	6 058 mm	12 192 mm	13 716 mm	2 438 mm	2 591 mm	2 896 mm
Minimum Internal Dimensions	5 867 mm 19'3"	11 998 mm 39'4 ³ / ₈ "	13 532 mm 44'4 ³ / ₄ "	2 197 mm 7'2 ¹ / ₂ "	2 350 mm 7'8 ¹ / ₂ "	2 655 mm 8'8 ¹ / ₂ "
Minimum Door Opening Dimensions	–	–	–	2 134 mm 7'	2 261 mm 7'5"	2 566 mm 8'5"

General Purpose Container

20'

ISO Size Type Code: 22 G0
(22 G1)



- Suitable for any general cargo.
- Containers may be equipped with liner bags suitable for bulk cargo, e.g. malt.
- Fork-lift pockets for loaded containers.
- Floor Height 170 mm - 5mm (Ground level to interior floor surface)
- Various lashing devices on the top and bottom longitudinal rails and the corner posts.
- Lashing devices have a load of 1 000 kg (2 205 lbs) each.

General Purpose Container

20'

Construction	Inside Dimensions			Door Opening		Weights			Capacity m ³ cu.ft
	Length	Width	Height	Width	Height	Max. Gross	Tare	Max. Payload	
	mm ft	mm ft	mm ft	mm ft	mm ft	kg lbs	kg lbs	kg lbs	

Hapag-Lloyd Serial Number	Foot-note
---------------------------	-----------

8'6" high

Steel container with corrugated walls and wooden floor	5 895 19'4 1/8"	2 350 7'8 1/2"	2 392 7'10 1/8"	2 340 7'8 1/8"	2 292 7'6 1/4"	30 480 67 200	2 250 4 960	28 230 62 240	33,2 1172
	5 900 9'4 1/4"	2 352 7'8 5/8"	2 395 7'10 1/4"	2 340 7'8 1/8"	2 292 7'6 1/4"	32 500 71 650	2 370 5 220	30 130 66 430	33,2 1172
	5 895 19'4 1/8"	2 350 7'8 1/2"	2 385 7'9 7/8"	2 338 7'8"	2 292 7'6 1/4"	24 000 52 910	2 250 4 960	21 750 47 950	33,2 1172

HLCU 200 000 – 226 599 HLCU 240 000 – 243 899 HLCU 246 750 – 246 779 HLXU 200 000 – 212 799 HLXU 212 800 – 239 799 HLXU 300 000 – 310 099	1) 1)2)3) 1)2)3)
HLXU 310 100 – 337 999	1)2)3)
HLCU 227 000 – 229 499	1)

Construction	Inside Dimensions				Weights			Capacity m ³ cu.ft
	Length	Width	Height		Max. Gross	Tare	Max. Payload	
			Middle	Side				
mm ft	mm ft	mm ft	mm ft	mm ft	kg lbs	kg lbs	kg lbs	

Hapag-Lloyd Serial Number	Foot-note
---------------------------	-----------

8'6" high ISO Size Type Code: 22U6

Steel container with corrugated walls, wooden floor and removable steel roof	5 886 19'3 3/4"	2 342 7'8 1/8"	2 388 7'10"	2 313 7'7"	30 480 67 200	2 700 5 950	27 780 61 250	32,8 1160
	5 886 19'3 3/4"	2 342 7'8 1/8"	2 388 7'10"	2 313 7'7"	30 480 67 200	2 700 5 950	27 780 61 250	32,8 1160
	5 886 19'3 3/4"	2 342 7'8 1/8"	2 375 7'9 1/2"	2 330 7'7 3/4"	30 480 67 200	2 590 5 710	27 890 61 490	32,8 1160

HLCU 260 200 – 261 399 HLXU 365 000 – 366 299	4)
HLCU 261 400 – 261 799	4)
HLCU 261 800 – 261 999 HLCU 262 600 – 262 999	4)

Remarks:

- 1) 10 lashing rings on each top longitudinal rail; particularly suitable for the transport of hanging garments racks.
- 2) Provided with passive vents. ISO size type code: 22G1
- 3) Provided with extra lashing rings/bars for the transport of liner bags in the corner posts adjacent to the corner castings.
- 4) For special information please see 20' Hard Top Container.

General Purpose Container

40'

ISO Size Type Code: 42 G0
(42 G1)



- Suitable for any general cargo.
- Floor Height 170 mm - 5mm (Ground level to interior floor surface)
- 21 lashing rings on each top longitudinal particularly suitable for the transport of hanging garment equipment. Lashing devices have a permissible load of 1000 kg (2 205 lbs) each.

General Purpose Container

40'

Construction	Inside Dimensions			Door Opening		Weights			Capacity m ³ cu.ft
	Length	Width	Height	Width	Height	Max. Gross	Tare	Max. Payload	
	mm ft	mm ft	mm ft	mm ft	mm ft	kg lbs	kg lbs	kg lbs	

Hapag-Lloyd Serial Number	Foot-note
---------------------------	-----------

8'6" high

Steel container with corrugated walls and wooden floor	12 029 39'5½"	2 350 7'8½"	2 392 7'10½"	2 340 7'8⅛"	2 292 7'6¼"	30 480 67 200	3 780 8 330	26 700 58 870	67,7 2 390
	12 032 39'5⅝"	2 352 7'8⅝"	2 395 7'10¼"	2 340 7'8⅛"	2 292 7'6¼"	32 500 71 650	4 030 8 885	28 470 62 765	677 2 390
	12 032	2 352	2 395	2 340	2 292	32 500	3 980	28 520	67,7

HLCU 400 000 – 428 599 HLXU 400 000 – 449 999 HLXU 500 000 – 507 749	1)
HLXU 507 750 – 511 349 HLXU 511 350 – 525 799	

Construction	Inside Dimensions				Weights			Capacity m ³ cu.ft
	Length	Width	Height		Max. Gross	Tare	Max. Payload	
			Middle	Side				
mm ft	mm ft	mm ft	mm ft	mm ft	kg lbs	kg lbs	kg lbs	

Hapag-Lloyd Serial Number	Foot-note
---------------------------	-----------

8'6" high ISO Size Type Code: 42U6

Steel container with corrugated walls, wooden floor and removable steel roof	12 020 39'5¼"	2 342 7'8⅛"	2 388 7'10"	2 313 7'7"	30 480 67 200	4 700 10 360	25 780 56 840	67,2 2 374
	12 020 39'5¼"	2 342 7'8⅛"	2 388 7'10"	2 313 7'7"	30 480 67 200	4 700 10 360	25 780 56 840	67,2 2 374
	12 020 39'5¼"	2 345 7'8¼"	2 380 7'9⅝"	2 300 7'6½"	30 480 67 200	4 700 10 360	25 780 56 840	65,3 2 306

HLCU 462 100 – 462 399	3)
HLCU 462 400 – 463 999 HLXU 465 000 – 466 249	3) 3)
HLXU 467 950 – 467 999	3)

Remarks:

1) no passive vents.

3) Special information, please see 40' Hard Top Container.

High Cube General Purpose Container

40'

ISO Size Type Code: 45 G0
(45 G1)



- Especially for voluminous cargo up to max. 2.70 m (8'10¹/₄"') (see table).
- Numerous lashing devices on the top and bottom longitudinal rails and the corner posts.
- Lashing devices have a permissible load of 1000 kg (2 205 lbs) each.
- Floor Height 170 mm - 5mm (Ground level to interior floor surface)
- **Consider overheight for inland transportation**
- Provided with passive vents. ISO size type code: 45 G1

High Cube General Purpose Container

40'

Construction	Inside Dimensions			Door Opening		Weights			Capacity m ³ cu.ft
	Length	Width	Height	Width	Height	Max. Gross	Tare	Max. Payload	
	mm ft	mm ft	mm ft	mm ft	mm ft	kg lbs	kg lbs	kg lbs	

Hapag-Lloyd Serial Number	Foot-note
---------------------------	-----------

9'6" high

Steel container with corrugated walls and wooden floor	12 024 39'5 ⁵ / ₈ "	2 350 7'8 ¹ / ₂ "	2 697 8'10 ¹ / ₈ "	2 340 7'8 ¹ / ₈ "	2 597 8'6 ¹ / ₄ "	30 480 67 200	4 020 8 860	26 460 58 340	76,3 2 694
	12 032 39'5 ⁵ / ₈ "	2 350 7'8 ¹ / ₂ "	2 699 8'10 ¹ / ₄ "	2 340 7'8 ¹ / ₈ "	2 597 8'6 ¹ / ₄ "	30 480 67 200	4 000 8 818	26 480 58 378	76,3 2 694
	12 032 39'5 ⁵ / ₈ "	2 352 7'8 ⁵ / ₈ "	2 700 8'10 ¹ / ₄ "	2 340 7'8 ¹ / ₈ "	2 597 8'6 ¹ / ₄ "	32 500 71 650	4 010 8 840	28 490 62 810	76,3 2 694

HLCU 457 000 – 459 799 HLXU 450 000 – 459 899	
HLCU 453 800 – 454 999 HLXU 600 000 – 632 899	
HLXU 632 900 – 655 499	

Construction	Inside Dimensions				Weights			Capacity m ³ cu.ft
	Length	Width	Height		Max. Gross	Tare	Max. Payload	
			Middle	Side				
mm ft	mm ft	mm ft	mm ft	mm ft	kg lbs	kg lbs	kg lbs	

Hapag-Lloyd Serial Number	Foot-note
---------------------------	-----------

9'6" high ISO Size Type Code: 45U6

Steel container with corrugated walls, wooden floor and removable steel roof	12 020 39'5 ¹ / ₄ "	2 342 7'8 ¹ / ₈ "	2 693 8'10"	2 618 8'7"	30 480 67 200	4 900 10 803	25 580 56 394	75,8 2 677
	12 020 39'5 ¹ / ₄ "	2 342 7'8 ¹ / ₈ "	2 693 8'10"	2 618 8'7"	32 500 71 650	5 200 11 436	27 300 60 180	76,0 2 684

HLXU 467 000 – 467 299	3)
HLXU 665 000 – 666 049	3)

Remarks:

- 21 lashing rings on each top longitudinal rail; particularly suitable for the transport of hanging garment equipment.
- 3) Special information, please see 40' High Cube Hard Top Container.

High Cube General Purpose Container

45'

ISO Size Type Code: L5GP
(L5G1)

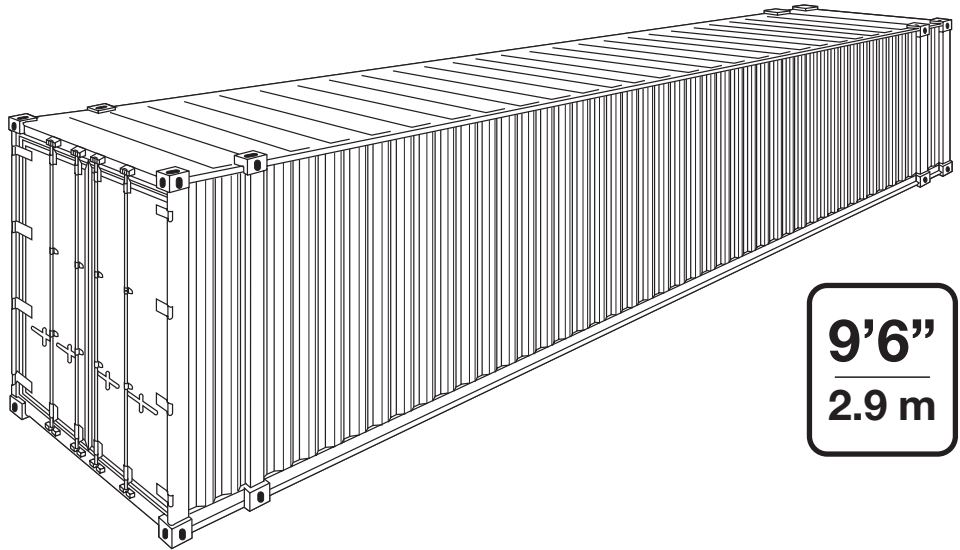

- Especially for voluminous cargo up to max. 2.70 m (8'10¹/₄"') (see table).
- 10 Lashing rings on the top and bottom longitudinal rails. Total 40 piece.
- Units built with corner castings at 40 ft and 45 ft positions.
- Lashing devices have a permissible load of 1000 kg (2 205 lbs) each.
- Floor Height 170 mm - 5mm (Ground level to interior floor surface)
- **Consider overheight for inland transportation**
- **Extended by length.**

High Cube General Purpose Container

45'

Construction	Inside Dimensions			Door Opening		Weights			Capacity
	Length	Width	Height	Width	Height	Max. Gross	Tare	Max. Payload	
	mm ft	mm ft	mm ft	mm ft	mm ft	kg lbs	kg lbs	kg lbs	

Hapag-Lloyd Serial Number	Foot- note
---------------------------------	---------------

9'6" high

Steel container with corrugated walls and wooden floor	13 532 44' 4 ³ / ₄ "	2 414 7'11"	2 694 8'10"	2 374 7'9 ¹ / ₂ "	2 585 8'5 ³ / ₄ "	34 000 74 960	4 950 10 910	29 050 64 050	88,4 3 122
	13 557 44'5 ³ / ₄ "	2 353 7'8 ⁵ / ₈ "	2 700 8'10 ¹ / ₄ "	2 340 7'8 ¹ / ₈ "	2 585 8'5 ³ / ₄ "	30 420 67 064	4 820 10 626	25 660 56 570	86,1 3 041

UESU 482 601 – 483 100	
UESU 483 751 – 484 750	

Remarks:

Provided with passive vents. ISO size type code: L5 G1

Hardtop Container

20'

ISO Size Type Code: 22 U6

- This container type has been designed and developed by Hapag-Lloyd.
- It has especially been constructed for
 - heavy loads
 - high, and excessively high loads
 - loading, e.g. by crane, through roof opening and door side.
- Floor Height 170 mm - 5mm (Ground level to interior floor surface)
- With the roof removed and the door-header swung out, it is much easier to load cargo using a crane via the door side.
- The steel roof of most series (please see footnote) is fitted with fork-lift rings so that it can be removed by using a forklift. The weight of the steel roof is approx. 450 kg (990 lbs).
- In case your cargo has overheight the roof sections can be lashed to a side-wall inside the container using only some 13 cm (5 1/8) of space.
- If required, we can provide disposable tarpaulins for the transport which can be fastened to the walls on the outside using lashing devices.



- The hardtop container provides many lashing devices to fasten your goods. The lashing devices on the corner posts and on the longitudinal rails of the roof and floor are capable of bearing loads of up to 2,000 kg (4,410 lbs) each, and those in the middle of the side walls up to 500 kg (1,100 lbs) each. Lashing to the side walls can only be done after the roof has been closed.
- Fork-lift pockets for loaded containers.
- Utilizable for bulk cargo.

By request, we can provide filler from top. Please contact our nearest HLCL office

- This container type has been designed for heavy loads. Whilst considering the technical data (including the permissible spreaded load limitations) please bear in mind the prevalent weight restrictions for land transport.
- For further information please see page 16 and our brochure “Hardtop Design”.

Hardtop Container

20'

Construction	Inside Dimensions				Weights			Capacity m ³ cu.ft
	Length mm ft	Width mm ft	Height		Max. Gross kg lbs	Tare kg lbs	Max. Payload kg lbs	
			Middle mm ft	Side mm ft				

Hapag-Lloyd Serial Number	Foot- note
---------------------------------	---------------

8'6" high

Steel container with corrugated walls, wooden floor and removable steel roof	5 886 19'3 ³ / ₄ "	2 342 7'8' ¹ / ₈ "	2 388 7'10"	2 313 7'7"	30 480 67 200	2 700 5 950	27 780 61 250	32,8 1160
	5 886 19'3 ³ / ₄ "	2 342 7'8' ¹ / ₈ "	2 388 7'10"	2 313 7'7"	30 480 67 200	2 700 5 950	27 780 61 250	32,8 1160
	5 886 19'3 ³ / ₄ "	2 342 7'8' ¹ / ₈ "	2 375 7'9' ¹ / ₂ "	2 330 7'7' ³ / ₄ "	30 480 67 200	2 590 5 710	27 890 61 490	32,8 1160

HLCU 260 200 – 261 399 HLXU 365 000 – 365 649	2) 3) 4)
HLCU 261 400 – 261 799	
HLCU 261 800 – 261 999 HLCU 262 600 – 262 999	1)

Remarks:

- 1) Roof without hinged rings.
- 2) Provided with passive vents. ISO size type code: 22 U6
- 3) 10 lashing rings on each top longitudinal rail; particularly suitable for the transport of hanging garment equipment.
- 4) Provided with extra lashing rings/bars for the transport of liner bags in the corner post adjacent to the corner castings.

Roof and door openings please see next page.

Roof and Door Openings of Hardtop Containers

20'

Roof Openings

Length	Width
B Between gusset plates mm ft	C Max. mm ft

8'6" high

5 590 18'4"	2 208 7'2 ⁷ / ₈ "
5 590 18'4"	2 208 7'2 ⁷ / ₈ "
5 590 18'4"	2 208 7'2 ⁷ / ₈ "

Door Openings

Width			Height	
F	G	H	I	K
Max.	At door header	Between top rails	Up to door header	Up to top rail
mm ft	mm ft	mm ft	mm ft	mm ft

2 336 7'8"	1 896 6'2 ⁵ / ₈ "	2 208 7'2 ⁷ / ₈ "	2 276 7'5 ⁵ / ₈ "	2 220 7'3 ³ / ₈ "
2 336 7'8"	1 896 6'2 ⁵ / ₈ "	2 208 7'2 ⁷ / ₈ "	2 292 7'6 ¹ / ₄ "	2 220 7'3 ³ / ₈ "
2 336 7'8"	1 896 6'2 ⁵ / ₈ "	2 208 7'2 ⁷ / ₈ "	2 280 7'5 ³ / ₄ "	2 231 7'3 ³ / ₄ "

Roof lashed to sidewall

Reduced Inside Width		
Max.	Roof opening	Door opening
mm ft	mm ft	mm ft

2 209 7'3"	2 142 7'1 ¹ / ₄ "	2 206 7'2 ⁷ / ₈ "
2 209 7'3"	2 142 7'1 ¹ / ₄ "	2 206 7'2 ⁷ / ₈ "
2 215 7'3 ¹ / ₈ "	2 148 7'1 ¹ / ₂ "	2 212 7'3"

Hapag-Lloyd Serial Number
HLCU 260 200 – 261 399 HLXU 365 000 – 366 299
HLCU 261 400 – 261 799
HLCU 261 800 – 261 999 HLCU 262 600 – 262 999

Roof Openings

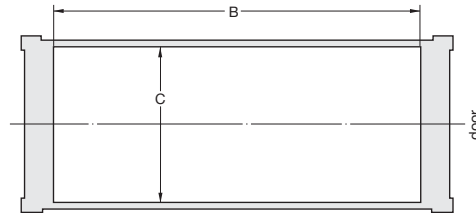

Door Openings

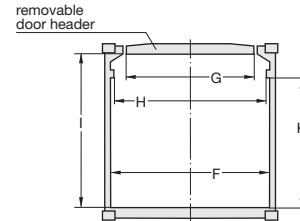

Hardtop Container

40'

ISO Size Type Code: 42 U6

- This container type has been designed and developed by Hapag-Lloyd.
- The 40' hardtop container has particularly been constructed for:
 - long loads which cannot be transported in the 20' hardtop container
 - heavy loads
 - high and excessively high loads
 - loading, e.g. by crane, through roof opening and door side.
- With the roof removed and the door header swung out, it is much easier to load cargo using a crane via the door side.
- Provided with lifting devices by fork-lift truck or crane. The weight of the single steel roof comes within the limits of approx. 450 kg (990 lbs).
- In case your cargo has overheight the roof sections can be lashed to a side-wall inside the container using only some 13 cm (5 1/8") of space.
- Floor Height 170 mm - 5mm (Ground level to interior floor surface)
- If required, we can provide disposable tarpaulins for the transport which can



be fastened to the walls on the outside using lashing devices.

- The hardtop container provides many lashing devices to fasten your goods. The lashing devices on the corner posts and on the longitudinal rails of the roof and floor are capable of bearing loads of up to 2,000 kg (4,410 lbs) each, and those in the middle of the side walls up to 500 kg (1,100 lbs) each. Lashing to the side walls can

only be done after the roof has been closed.

- The roof can easily be raised by about 70 mm (2 3/4), using the roof locking devices so that the door-header can be swung out without removing the roof.
- This container type has been designed for heavy loads. Whilst considering the technical data (including the permissible spreaded load limitations) please bear in mind the prevalent weight restrictions for land transport.
- For further information please see page 19 and our brochure "Hardtop Design".

Hardtop Container

40'

Construction	Inside Dimensions				Weights			Capacity m ³ cu.ft
	Length mm ft	Width mm ft	Height		Max. Gross kg lbs	Tare kg lbs	Max. Payload kg lbs	
			Middle mm ft	Side mm ft				

Hapag-Lloyd Serial Number	Foot- note
---------------------------------	---------------

8'6" high

Steel container with corrugated walls, wooden floor and removable steel roof	12 020 39'5¼"	2 342 7'8⅛"	2 388 7'10"	2 313 7'7"	30 480 67 200	4 700 10 360	25 780 56 840	67,2 2374
	12 020 39'5¼"	2 342 7'8⅛"	2 388 7'10"	2 313 7'7"	30 480 67 200	4 700 10 360	25 780 56 840	67,2 2374
	12 020 39'5¼"	2 345 7'8¼"	2 380 7'9⅝"	2 300 7'6½"	30 480 67 200	4 700 10 360	25 780 56 840	65,3 2306

HLCU 462 100 – 462 399	
HLCU 462 400 – 463 999 HLXU 465 000 – 466 249	
HLXU 467 950 – 467 999	1)

Remarks:

The 40' hardtop has a removable turnbuckle positioned dead centre between both top rails.

This may reduce the cargo height, if left in position and not stored.

1) Special design, roof locking clips.

Roof and door openings please see next page.

Roof and Door Openings of Hardtop Containers

40'

Roof Openings

Length	Width
B Between gusset plates mm ft	C Max. mm ft

8'6" high

11 724 38'5 1/2"	2 208 7'2 7/8"
11 724 38'5 1/2"	2 208 7'2 7/8"
11 724 38'5 1/2"	2 208 7'2 7/8"

Door Openings

Width			Height	
F	G	H	I	K
Max.	At door header	Between top rails	Up to door header	Up to top rail
mm ft	mm ft	mm ft	mm ft	mm ft

2 336 7'8"	1 896 6'2 5/8"	2 208 7'2 7/8"	2 292 7'6 1/4"	2 220 7'3/8"
2 336 7'8"	1 896 6'2 5/8"	2 208 7'2 7/8"	2 276 7'5 5/8"	2 220 7'3/8"
2 334 7'7 7/8"	1 882 6'2 1/2"	2 208 7'2 7/8"	2 290 7'6 1/8"	2 125 6'11 5/8"

Roof lashed to sidewall

Reduced Inside Width		
Max.	Roof opening	Door opening
mm ft	mm ft	mm ft

2 209 7'3"	2 142 7'1 1/4"	2 206 7'2 7/8"
2 209 7'3"	2 142 7'1 1/4"	2 206 7'2 7/8"
2 205 7'2 3/4"	2 102 6'10 3/4"	1 996 6'6 1/2"

Hapag-Lloyd Serial Number

HLCU 462 100 – 462 399
HLCU 462 400 – 463 999 HLXU 465 000 – 466 249
HLXU 467 950 – 467 999

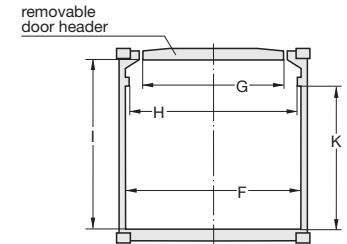
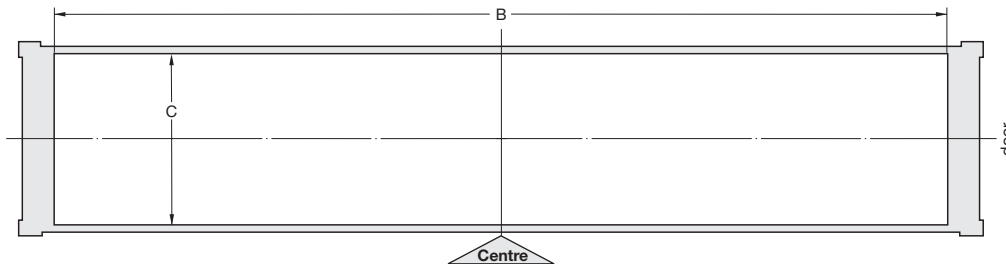

"Attention" Reduced inside height due to adjust bar, in the centre ~ -160 mm

High Cube Hardtop Container

40'

ISO Size Type Code: 45 U6

- This container type has been designed and developed by Hapag-Lloyd.
- The 40' hardtop container has particularly been constructed for:
 - long loads which cannot be transported in the 20' hardtop container
 - heavy loads
 - high and excessively high loads
 - loading, e.g. by crane, through roof opening and door side.
- With the roof removed and the door header swung out, it is much easier to load cargo using a crane via the door side.
- The roof can be removed by using a fork-lift. The weight of the steel roof is approx. 450 kg (990 lbs) each section.
- In case your cargo has overheight the roof sections can be lashed to a side-wall inside the container using only some 13 cm (5 1/8") of space.
- Floor Height 170 mm - 5mm (Ground level to interior floor surface)
- If required, we can provide disposable tarpaulins for the transport which can



be fastened to the walls on the outside using lashing devices.

- The hardtop container provides many lashing devices to fasten your goods. The lashing devices on the corner posts and on the longitudinal rails of the roof and floor are capable of bearing loads of up to 2,000 kg (4,410 lbs) each, and those in the middle of the side walls up to 500 kg (1,100 lbs) each. Lashing to the side walls can only be done after the roof has been closed.

- The roof can easily be raised by about 70 mm (2 3/4), using the roof locking devices so that the door-header can be swung out without removing the roof.
- This container type has been designed for heavy loads. Whilst considering the technical data (including the permissible spreaded load limitations) please bear in mind the prevalent weight restrictions for land transport.
- For further information please see page 22 and our brochure "Hardtop Design".

High Cube Hardtop Container

40'

Construction	Inside Dimensions				Weights			Capacity m ³ cu.ft
	Length mm ft	Width mm ft	Height		Max. Gross kg lbs	Tare kg lbs	Max. Payload kg lbs	
			Middle mm ft	Side mm ft				

9'6" high

Steel container with corrugated walls, wooden floor and removable steel roof	12 020 39'5 ¹ / ₄ "	2 342 7'8 ¹ / ₈ "	2 693 8'10"	2 618 8'7"	30 480 67 200	4 900 10 803	25 580 56 394	75,8 2 677
	12 021 39'5 ⁵ / ₁₄ "	2 346 7'8 ³ / ₈ "	2 695 8'10 ¹ / ₈ "	2 620 8'7 ¹ / ₈ "	30 480 67 200	4 900 10 803	25 580 56 394	76,0 2 684
	12 022 39'5 ¹ / ₄ "	2 346 7'8 ³ / ₈ "	2 695 8'10 ¹ / ₈ "	2 620 8'7 ¹ / ₈ "	32 500 72 650	5 200 11 470	27 300 60 180	76,0 2 684

Hapag-Lloyd Serial Number	Foot-note
---------------------------	-----------

HLXU 467 000 - 467 299	
HLXU 665 000 - 665 199	
HLXU 665 200 - 666 049	

Remarks:

Roof with hinged rings for easy removal by a fork-lift truck.

ISO size type code: 45 U6

18 lashing rings on each top longitudinal rail; particularly suitable for the transport of hanging garment equipment.

The 40' hardtop has a removable turnbuckle positioned dead centre between both top rails.

This may reduce the cargo height, if left in position and not stored.

Roof and door openings please see next page.

Roof and Door Openings of Hardtop Containers

40'

Roof Openings

Length	Width
B Between gusset plates mm ft	C Max. mm ft

9'6" high

11 724 38'5 1/2"	2 208 7'27 7/8"
11 724 38'5 1/2"	2 212 7'27 7/8"

Door Openings

Width			Height	
F	G	H	I	K
Max.	At door header	Between top rails	Up to door header	Up to top rail
mm ft	mm ft	mm ft	mm ft	mm ft

2 336 7'8"	1 896 6'25 5/8"	2 208 7'27 7/8"	2 597 8'6 1/4"	2 525 8'3 3/8"
2 346 7'8"	1 957 6'25 5/8"	2 232 7'27 7/8"	2 581 8'6 1/4"	2 523 8'3 3/8"

Roof lashed to sidewall

Reduced Inside Width		
Max.	Roof opening	Door opening
mm ft	mm ft	mm ft

2 230 7'3 3/4"	2 163 7'11 1/8"	2 227 7'35 5/8"
2 230 7'3 3/4"	2 161 7'11 1/8"	2 227 7'35 5/8"

Hapag-Lloyd Serial Number

HLXU 467 100 – 467 299
HLXU 665 000 – 666 049

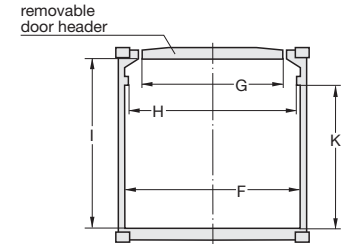
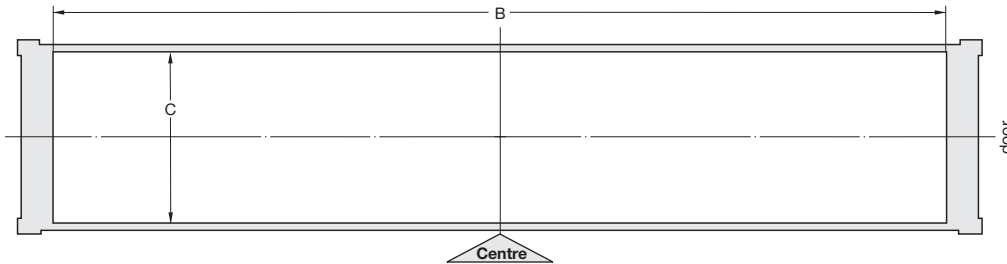

“Attention” internal height 2 541 mm when adjust bar inserted

Open Top Container

20'

ISO Size Type Code: 22 U1

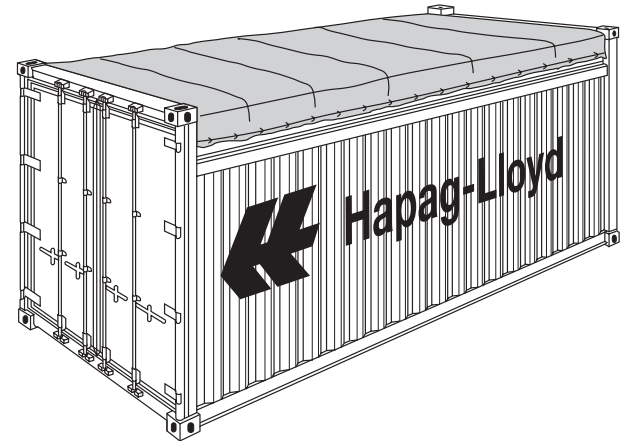

- Especially for
 - overheight cargo
 - loading from top side, e.g. by crane
 - loading from door side, e.g. with cargo hanging from overhead tackle
- Floor Height 170 mm - 5mm (Ground level to interior floor surface)
- Door header can be swung out on all open top containers
- If required, we can provide disposable tarpaulins. For fastening tarpaulins, lashing bars are available on the outside of the walls. Using one way tarpaulins requires the corner castings to be accessible.
- Fork-lift pockets for loaded containers.
- Numerous lashing devices on the top and bottom longitudinal rails and the corner posts. Lashing devices have a permissible load of 1000 kg (2 205 lbs) each.
- **Dimensions of roof and door openings please see page 25.**

Open Top Container

20'

Construction	Inside Dimensions				Weights			Capacity m ³ cu.ft
	Length mm ft	Width mm ft	Height		Max. Gross kg lbs	Tare kg lbs	Max. Payload kg lbs	
			Middle mm ft	Side mm ft				

Hapag-Lloyd Serial Number	Foot- note
---------------------------------	---------------

8'6" high

Steel container with corrugated walls, wooden floor and removable tarpaulin	5 888 19'3 ³ / ₄ "	2 345 7'8 ¹ / ₈ "	2 365 7'9"	2 315 7'7 ¹ / ₈ "	30 480 67 200	2 250 4 960	28 230 62 240	32,0 1 130
	5 897 19'4 ¹ / ₈ "	2 350 7'8 ¹ / ₂ "	2 377 7'9 ¹ / ₂ "	2 347 7'8 ³ / ₈ "	30 480 67 200	2 350 5 180	28 130 62 020	32,5 1 146
	5 895 19'4 ¹ / ₈ "	2 350 7'8 ¹ / ₂ "	2 380 7'9 ⁵ / ₈ "	2 346 7'8 ³ / ₈ "	32 500 71 650	2 250 4 960	30 250 66 690	32,5 1 114

HLCU 264 600 – 264 899 HLXU 260 000 – 260 849	
HLXU 260 850 – 261 599	
HLXU 360 000 – 361 549	1)

Remarks :

1) Concentrated load up increased from 4 tons per running meter in length (3'3³/₈"

Roof and door openings please see next page.

Open Top Container

20'

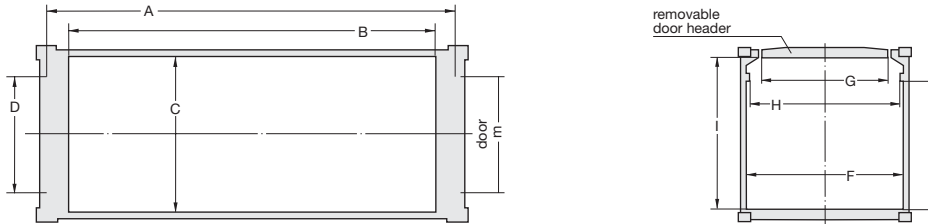

Roof Openings

Length		Width		
A	B	C	D	E
Max.	Between gusset plates	Max.	Front between gussets	Door between gussets
mm	mm	mm	mm	mm
ft	ft	ft	ft	ft

Door Openings

F	Width		Height	
	G	H	I	K
Max.	At door header	Between top rails	Up to door header	Up to top rail
mm	mm	mm	mm	mm
ft	ft	ft	ft	ft

Hapag-Lloyd Serial Number

8'6" high

5 415 17'9 ¹ / ₈ "	5 360 17'7"	2 205 7'2 ³ / ₄ "	na na	1 880 6'2"
5 439 18'4"	5 338 17'6 ¹ / ₈ "	2 230 7'3 ³ / ₄ "	na na	1 902 6'2 ⁷ / ₈ "
5 418 18'4"	5 338 17'6 ¹ / ₈ "	2 230 7'3 ³ / ₄ "	na na	1 902 6'2 ⁷ / ₈ "

2 335 7'8"	1 880 6'2"	2 205 7'2 ³ / ₄ "	2 280 7'5 ³ / ₄ "	2 125 6'11 ⁵ / ₈ "
2 338 7(8)	1 902 6'2 ⁷ / ₈ "	2 230 7'3 ³ / ₄ "	2 280 7'5 ³ / ₄ "	2 231 7'1"
2 338 7'8"	1 899 6'2 ⁷ / ₈ "	2 230 7'3 ³ / ₄ "	2 280 7'5 ³ / ₄ "	2 231 7'1"

HLCU 264 600 – 264 899 HLXU 260 000 – 260 849
HLXU 260 850 – 261 599
HLXU 360 000 – 361 549

Open Top Container

40'

ISO Size Type Code: 42 U1



- Especially for
 - overheight cargo
 - loading from top side, e.g. by crane
 - loading from door side, e.g. with cargo hanging from overhead tackle
- Floor Height 170 mm - 5mm (Ground level to interior floor surface)
- Door header can be swung out on all open top containers
- Numerous lashing devices on the top and bottom longitudinal rails and the corner posts. Lashing devices have a permissible load of 1 000 kg (2 205 lbs) each.
- **Dimensions of roof and door openings please see page 28.**

Open Top Container

40'

Construction	Inside Dimensions				Weights			Capacity m ³ cu.ft
	Length mm ft	Width mm ft	Height		Max. Gross kg lbs	Tare kg lbs	Max. Payload kg lbs	
			Middle mm ft	Side mm ft				

Hapag-Lloyd Serial Number	Foot- note
---------------------------------	---------------

8'6" high

Steel container with corrugated walls, wooden floor and removable tarpaulin	12 029 39'5½"	2 342 7'8⅛"	2 376 7'9½"	2 326 7'7½"	30 480 67 200	3 810 8 400	26 670 58 800	65,5 2 310
	12 022 39'5¼"	2 345 7'8⅛"	2 365 7'9⅛"	2 315 7'7⅛"	30 480 67 200	3 740 8 245	26 740 58 955	65,3 2 306
	12 030 39'5⅝"	2 350 7'8½"	2 377 7'9½"	2 347 7'8⅜"	30 480 67 200	3 850 8 490	26 630 58 710	66,4 2 345
	12 029 39'5½"	2 350 7'8½"	2 380 7'9⅝"	2 346 7'8⅜"	32 500 71 650	4 050 8 929	28 450 62 721	66,8 2 359

HLCU 461 200 – 461 499	
HLCU 461 500 – 461 749 HLXU 460 000 – 460 799	
HLXU 460 800 – 462 119	
HLXU 560 000 – 562 249	

Roof and door openings please see next page.

Roof and Door Openings of Open Top Containers

40'

Roof Openings

Length	Width	
B	C	E Clearance between header stubs
mm ft	mm ft	mm ft

Door Openings

Width			Height	
F Max.	G Clearance between header stubs	C+H Between top rails	I Up to door header	K Up to top rail
mm ft	mm ft	mm ft	mm ft	mm ft

Hapag-Lloyd Serial Number

8'6" high

11 544 37'10½"	2 230 7'3¾"	1 885 6'2⅛"
11 550 37'10¾"	2 205 7'2¾"	1 880 6'2"
11 573 37'11⅝"	2 210 7'3"	1 902 6'27⁄8"
11 552 37'10¾"	2 230 7'3¾"	1 777 5'10"

2 336 7'8"	1 885 6'2⅛"	2 230 7'3¾"	2 280 7'5¾"	2 146 7'1½"
2 335 7'8"	1 880 6'2"	2 205 7'2¾"	2 280 7'5¾"	2 125 6'11⅝"
2 338 7'8"	1 902 6'27⁄8"	2 210 7'3"	2 292 7'6¼"	2 131 6'117⁄8"
2 340 7'8⅛"	1 777 5'10"	2 230 7'3¾"	2 276 7'5¾"	2 163 7'1⅛"

HLCU 461 200 – 461 499
HLCU 461 500 – 461 749 HLXU 460 000 – 460 799
HLXU 460 800 – 462 119
HLXU 560 000 – 562 249

Roof Openings

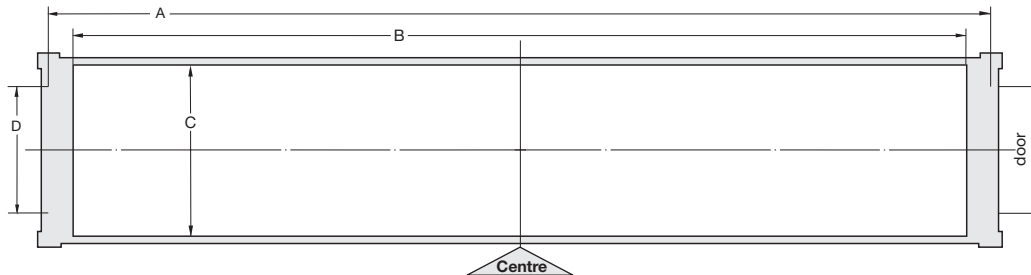

Door Openings

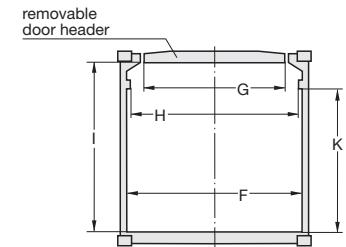

ISO Size Type Code: 8'6" high
(22 P3)
(22 P8)

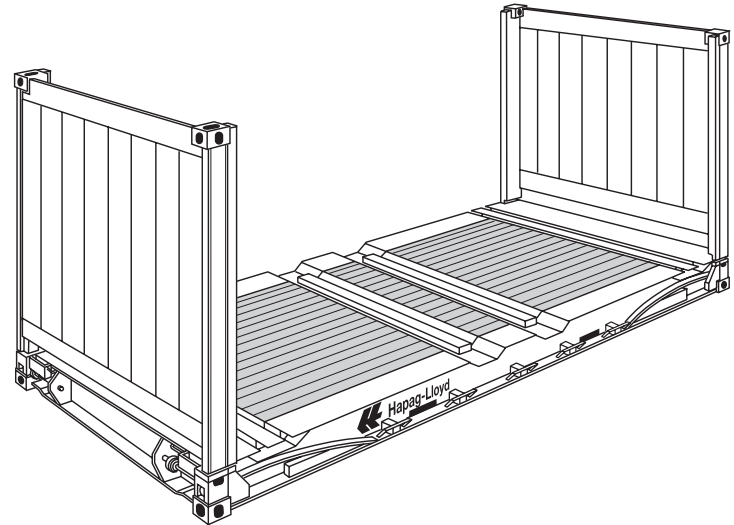

- Especially for heavy loads and over-size cargo as well as project cargo.
- Fork-lift pockets for loaded containers.
- Numerous very strong lashing devices on the corner posts, longitudinal rails and on the floor or base ends. Lashing devices on the longitudinal rails have a permissible load of 2 000 kg up to 5 000 kg each.
- **Maximum payload can only be used if distributed over the total floor area of flatrack. If concentration of heavy load on a small part of floor area is required please contact your Hapag-Lloyd partner office for stowage advice.**
- Flats are delivered without stanchions. If stanchions are required please inform us upon booking.
- Collapsible flatracks, provided with spring assisted endwalls.
- Collapsible flatracks, provided with twistlocks to interlock 7 units into a 8'6" high pile.

Flat

20'

Construction	Inside Dimensions						Weights		
	Length of floor	Length between posts	Width of floor	Width between side rails	Height floor to top face	Height of bottom	Max. Gross	Tare	Max. Payload
	mm ft	mm ft	mm ft	mm ft	mm ft	mm ft	kg lbs	kg lbs	kg lbs

8'6" high

Flat/Platform with flushfolding endwalls and softwood floor	5 850 19'2 1/4"	5 638 18'6"	2 438 8'	2 208 7'2 7/8"	2 233 7'3 7/8"	370 1'2 1/2"	40 000 88 184	2 940 6 482	37 060 81 702
Steelframe with collapsible endwalls and softwood floor	5 950 19'6 1/4"	5 675 18'7 3/8"	2 428 7'11 5/8"	2 213 7'3 1/8"	2 270 7'5 3/8"	316 1'3 3/8"	33 000 72 752	2 600 5 732	30 150 67 020
Flat/Platform with flushfolding endwalls and softwood floor	6038 19'9 3/4"	5638 18'6"	2 435 7'11 7/8"	2 208 7'2 7/8"	2235 7'4"	370 1'2 1/2"	30 480 67 200	2 520 5 560	27 960 61 640
	6038 19'9 3/4"	5612 18'4 7/8"	2 438 8'	2 210 7'3"	2213 7'3 1/8"	370 1'2 1/2"	34 000 74 950	2 740 6 040	31 260 68 910

Hapag-Lloyd Serial Number	Foot-note
---------------------------	-----------

HLXU 368 000 – 368 499	
HLXU 268 000 – 268 149	1)
HLXU 268 500 – 268 599	
HLXU 268 600 – 269 399	

Remarks:

1) ISO size type code: 22 P3

High Cube Flat

40'

ISO Size Type Code: 45 P8

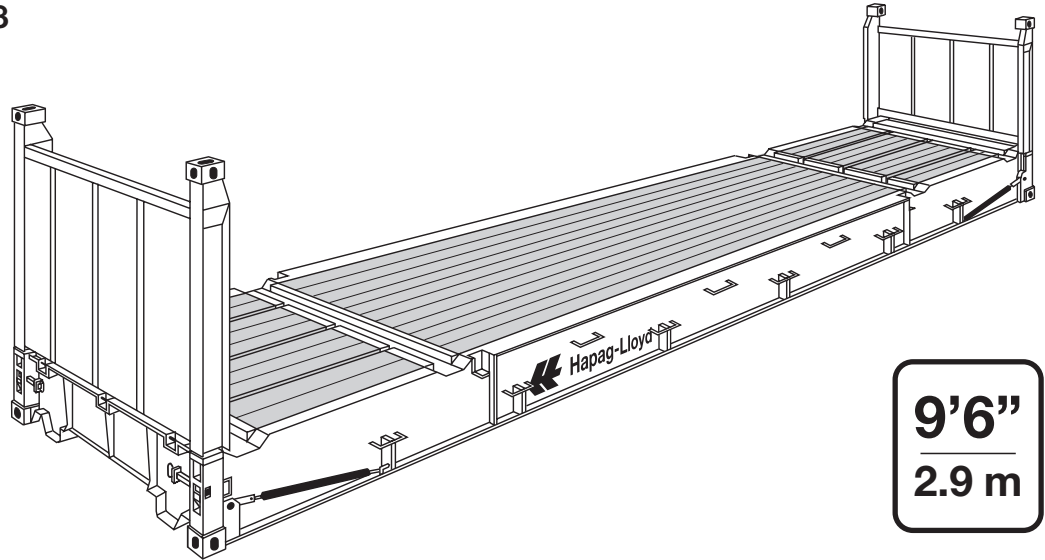

9'6"
2.9 m

- Especially for heavy loads and oversize cargo as well as project cargo.
- Extraordinary very strong frame design with folding endwalls which allow bracing and lashing as well as stacking.
- Collapsible flatracks, provided with twistlocks to interlock 4 units into a 8'6" high pile.
- Collapsible flatracks, provided with spring assisted endwalls.
- Used as "Tweendecks" in holds and on hatch covers for oversized cargoes.
- Numerous very strong lashing devices on longitudinal rails and base ends have a permissible load of 5 000 kg each.
- Gooseneck tunnel on both ends of all 40' flats.
- **The permissible payload of the flat depends on the resting length of the cargo onto the floor.**
- **Maximum payload can only be used if distributed over the total floor area of the flatrack, if heavy loads are shorter, the payload is reduced. Hapag-Lloyd partner office will give stowage advice.**
- Heavy cargo must rest on the main girder.
- Flats are delivered without stanchions.

High Cube Flat

40'

Construction	Inside Dimensions						Weights		
	Length of floor	Length between corner posts	Width of floor	Width between side rails	Height	Height of bottom	Max. Gross	Tare	Max. Payload
	mm ft	mm ft	mm ft	mm ft	mm ft	mm ft	kg lbs	kg lbs	kg lbs

Hapag-Lloyd Serial Number	Foot-note
---------------------------	-----------

9'6" high

Steelframe with collapsible flush-folding endwalls – can be converted to a platform	12 060 39'6 ³ / ₄ "	11 660 38'3 ¹ / ₈ "	2 365 7'9 ¹ / ₈ "	2 200 7'2 ⁵ / ₈ "	2245 7'4 ³ / ₈ "	648 2'1 ¹ / ₂ "	45 000 99 210	5 700 12 570	39 300 86 640
	12 048 39'6 ¹ / ₄ "	11 652 38'3"	2 370 7'9 ¹ / ₈ "	2 200 7'2 ⁵ / ₈ "	2 258 7'4 ⁷ / ₈ "	648 2'1 ¹ / ₂ "	50 000 110 230	5 950 13 120	44 050 97 110

HLCU 468 400 – 468 599 HLXU 468 000 – 469 799	
HLXU 668 000 – 668 699 HLXU 668 700 – 669 999	1) 2)

Remarks:

Timber treated according to Australien requirements.

Folds 4 into 2591 mm (8'6").

ISO size type code: 45 P8

1) Upgrated 50 t

2) Lashing rings 17 each side

Flat-Collapsible and/or Convertible into a Platform

20'/40'

ISO Size Type Code: according to Flat Series

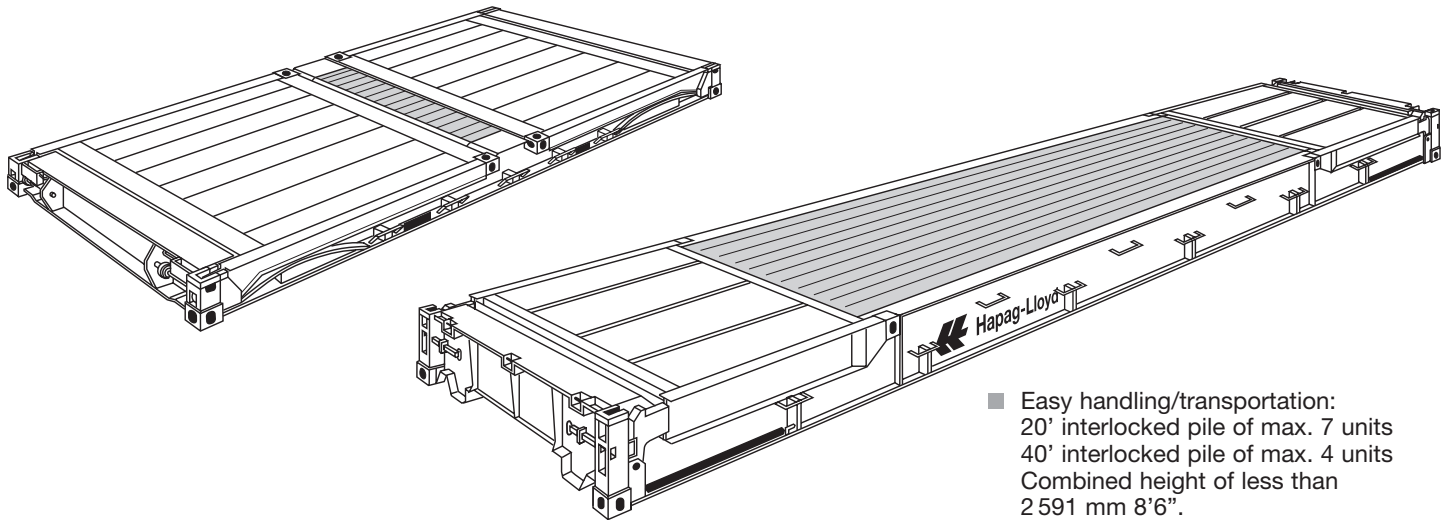

- Especially for heavy loads and oversized cargo.
- Strong bottom construction.
- Gooseneck tunnel on both ends of all 40' platforms.
- Static load up to 85 000 kg as a 40' foundation base. On request available
- Other features please see comparatively flat series.
- Timber treated according to Australian requirements.
- Numerous very strong lashing devices.
- Easy handling/transportation:
20' interlocked pile of max. 7 units
40' interlocked pile of max. 4 units
Combined height of less than 2 591 mm 8'6".
- Transport of heavy loads concentrated on a small load transfer area is possible.
- **Special requirements for big and more heavy cargoes, please contact our special cargo department. Solution plans are already worked out or will be calculated.**

Platform

20'/ 40'

Construction	Inside Dimensions			Weights		
	Length	Width	Height of bottom	Max. Gross	Tare	Max. Payload
	mm ft	mm ft	mm ft	kg lbs	kg lbs	kg lbs

Hapag-Lloyd Serial Number	Foot-note
---------------------------	-----------

1'11/4" high

20'

Steel container with collapsible flushfolding endwalls – can be converted to a platform	6 058 20'	2 438 8'	370 1'29/16"	30 480 67 200	2 520 5 560	27 960 61 640
	6 058 20'	2 438 8'	370 1'29/16"	34 000 74 950	2 740 6 040	31 260 68 910
	6 058 20'	2 438 8'	370 1'29/16"	40 000 88 180	2 940 6 480	37 060 81 700

HLXU 268 500 – 268 599	1)3)4)
HLXU 268 600 – 269 099	1)3)4)
HLXU 368 000 – 368 499	1)3)4)

2' high

40'

Steel container with collapsible flushfolding endwalls – can be converted to a platform	12 192 40'	2 245 7'43/8"	648 2'11/2"	45 000 99 210	5 700 12 570	39 300 86 640
	12 192 40'	2 245 7'43/8"	648 2'11/2"	50 000 110 230	5 950 13 120	44 050 97 110

HLCU 468 400 – 468 599	2)5)6)7)
HLXU 468 000 – 469 799	2)5)6)7)
HLXU 668 000 – 669 999	2)5)6)7)

Remarks:

- 1) Fork-lift pockets.
- 2) Useable as a foundation base,static load up to 85.000 kg on request available.
- 3) Folds 7 into 2591 mm (8'6").
- 4) ISO size type code: 22 P8.
- 5) Folds 4 into 2391 mm (8'6").
- 6) Equipped with 2 gooseneck tunnels.
- 7) ISO size type code: 45 P8.

Ventilated Container

20'

ISO Size Type Code: 22V0



- Especially for cargo which needs ventilation.
- Fork-lift pockets for loaded containers.
- Floor Height 170 mm - 5mm (Ground level to interior floor surface)
- Natural ventilation is provided by openings in top and bottom longitudinal rails.
The labyrinth construction of these ventilation openings ensures weather-proofness.
- Numerous lashing devices on the top and bottom longitudinal rails and the corner posts. Lashing devices have a permissible load of 1000 kg (2205 lbs) each.

Ventilated Container

20'

Construction	Inside Dimensions			Door Opening		Weights			Capacity
	Length	Width	Height	Width	Height	Max. Gross	Tare	Max. Payload	
	mm ft	mm ft	mm ft	mm ft	mm ft	kg lbs	kg lbs	kg lbs	

Hapag-Lloyd Serial Number	Foot-note
---------------------------	-----------

8'6" high

Steel container with corrugated walls and wooden floor	5 888 19'3 ³ / ₄ "	2 325 7'7 ¹ / ₂ "	2 392 7'10 ¹ / ₈ "	2 334 7'7 ⁷ / ₈ "	2 290 7'6 ¹ / ₈ "	30 480 67 200	2 400 5 290	28 080 61 910	33 1167
	5 895 19'4 ¹ / ₈ "	2 321 7'7 ³ / ₈ "	2 392 7'10 ¹ / ₈ "	2 340 7'8 ¹ / ₈ "	2 292 7'6 ¹ / ₄ "	30 480 67 200	2 490 5 490	27 990 61 710	33 1167

HLCU 255 500 – 256 999	
HLXU 250 000 – 250 599	
HLXU 250 600 – 251 749	2) 3)

Remarks:

- 10 lashing rings on each top longitudinal rail; particularly suitable for the transport of hanging garments racks.
- 2) Provided with extra lashing rings/bars for the transport of liner bags in the corner posts adjacent to the corner castings.
- 3) ISO size type code: 22 V0

Refrigerated Container (Temperature Controlled Container)

20'

ISO Size Type Code: 22 R1
(22 R9)

- State of the art insulation factors.
- Container available for set points as low as -35° C.
- De-humidification option available.
- Cold treatment available (USDA).
- 20' Boxes with up to 29.9 qm capacity.
- Controlled fresh-air supply with up to 280 qm/h.
- ATO-DLO certification for flowerbulk.
- Integrated datalogger storing temperatures and events hourly.
- Low power consumption.
- Only environmental friendly refrigerants used.
- Dedicated equipment for non-foodstuff cargoes.

- Other series solely for foodstuff cargoes.
- Please note maximum stowage height in below table and as indicated by red line inside the container in order to ensure proper air circulation.
- Voltages: 380 V/50 Hz to 460 V/60 Hz
- Technical specification and illustration of electric plugs see page 44.

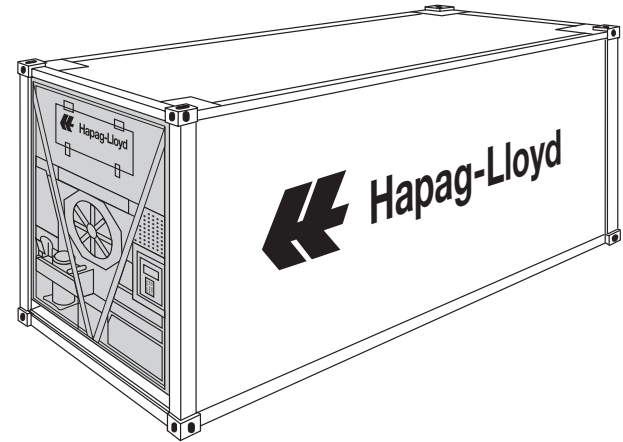

- The Container is designed to maintain the setpoint temperature.
- All cargo shall be pre-cooled to match the required in transit temperature.
- Especially for cargo which needs controlled temperatures above or below freezing point.
- Suitable for clip-on generators
- Freshair recording available

Refrigerated Container

20'

Containers are available for set points as low as **-35° C** and up to **+30° C**, please contact your local Hapag-Lloyd office for availability.

Construction	Inside Dimensions				Door Opening		Weights			Capacity m ³ cu.ft	Hapag-Lloyd Serial Number	Foot- note
	Length	Width	Height	Max. stow. Height	Width	Height	Max. Gross	Tare	Max. Payload			
	mm ft	mm ft	mm ft	mm ft	mm ft	mm ft	kg lbs	kg lbs	kg lbs			
8'6" high												
Steelframe, Sandwich walls	5 479 17'11 ⁵ / ₈ "	2 286 7'6"	2 257 7'4 ⁷ / ₈ "	2 157 7'7 ⁷ / ₈ "	2 286 7'6"	2 220 7'3 ³ / ₈ "	30 480 67 200	3 160 6 970	27 320 60 230	28,3 999	HLCU 270 521 – 271 070 HLCU 170 000 – 170 149	5)
	5 459 17'10 ⁷ / ₈ "	2 295 7'6 ³ / ₈ "	2 268 7'5 ¹ / ₄ "	2 168 7'1 ³ / ₈ "	2 291 7'6 ¹ / ₈ "	2 259 7'4 ⁷ / ₈ "	30 480 67 200	3 050 6 720	27 430 60 480	28,4 1003	HLCU 271 071 – 271 220	
	5 448 17'10 ¹ / ₂ "	2 290 7'6 ¹ / ₈ "	2 264 7'5 ¹ / ₈ "	2 164 7'1 ¹ / ₈ "	2 286 7'6"	2 260 7'5"	30 480 67 200	3 060 6 750	27 420 60 450	28,3 999	HLCU 271 221 – 271 470 HLXU 170 500 – 170 649	5)
	5 534 18'1 ⁷ / ₈ "	2 316 7'7 ¹ / ₈ "	2 331 7'7 ³ / ₄ "	2 231 7'3 ³ / ₄ "	2 316 7'7 ¹ / ₈ "	2 290 7'6 ¹ / ₈ "	30 480 67 200	3 030 6 680	27 450 60 520	29,9 1056	HLXU 270 000 – 270 499 HLXU 171 000 – 171 149	3) 3) 5)
	5 529 18'1 ⁵ / ₈ "	2 316 7'7 ¹ / ₈ "	2 331 7'7 ³ / ₄ "	2 290 7'6 ¹ / ₈ "	2 316 7'7 ¹ / ₈ "	2 290 7'6 ¹ / ₈ "	30 480 67 200	2 960 6 530	27 520 60 670	29,9 1056	HLXU 270 500 – 270 699	3) 4)
	5 535 18'1 ⁷ / ₈ "	2 284 7'5 ⁷ / ₈ "	2 270 7'5 ³ / ₈ "	2 224 7'3 ¹ / ₂ "	2 290 7'6 ¹ / ₈ "	2 264 7'5 ¹ / ₈ "	30 480 67 200	2 942 6 490	27 538 60 710	28,7 1014	HLXU 370 000 – 370 849	3) 4)

Remarks:

- 3) Prepared for being equipped with additional cargo temperature sensors (USDA).
- 4) De-humidification option installed.
- 5) **Not to be used for foodstuffs. ISO size type code: 22 R9**

Refrigerated Container

20'

Containers are available for set points as low as **-35° C** and up to **+30° C**, please contact your local Hapag-Lloyd office for availability.

Construction	Inside Dimensions				Door Opening		Weights			Capacity m ³ cu.ft	Hapag-Lloyd Serial Number	Foot- note
	Length mm ft	Width mm ft	Height mm ft	Max. stow. Height mm ft	Width mm ft	Height mm ft	Max. Gross kg lbs	Tare kg lbs	Max. Payload kg lbs			
8'6" high												
Steelframe, Sandwich walls	5 452 17'10 ⁵ / ₈ "	2 293 7'6 ¹ / ₄ "	2 252 7'4 ⁵ / ₈ "	2 152 7'3 ³ / ₄ "	2 290 7'6 ¹ / ₈ "	2 265 7'5 ¹ / ₈ "	30 480 67 200	3 160 6 970	27 320 60 230	28,3 999	HLXU 370 850 – 371 049	3) 4)
	5 450 17'10 ⁷ / ₈ "	2 284 7'6 ³ / ₈ "	2 267 7'5 ¹ / ₄ "	2 167 7'1 ³ / ₄ "	2 291 7'6 ¹ / ₈ "	2 259 7'4 ⁷ / ₈ "	30 480 67 200	3 050 6 720	27 430 60 480	28,4 1003	HLXU 371 050 – 371 249	3) 4)
	5 450 17'10 ⁷ / ₈ "	2 284 7'6 ³ / ₈ "	2 267 7'5 ¹ / ₄ "	2 221 7'3 ⁷ / ₁₆ "	2 291 7'6 ¹ / ₈ "	2 259 7'4 ⁷ / ₈ "	30 480 67 200	2 905 6 400	27 575 60 800	28,2 997	HLXU 371 250 – 372 299	3) 4)

Remarks:

- 3) Prepared for being equipped with additional cargo temperature sensors (USDA).
- 4) De-humidification option installed.

Refrigerated Container (Temperature Controlled Container)

40'

ISO Size Type Code: 45 R1 High Cube
42 R9

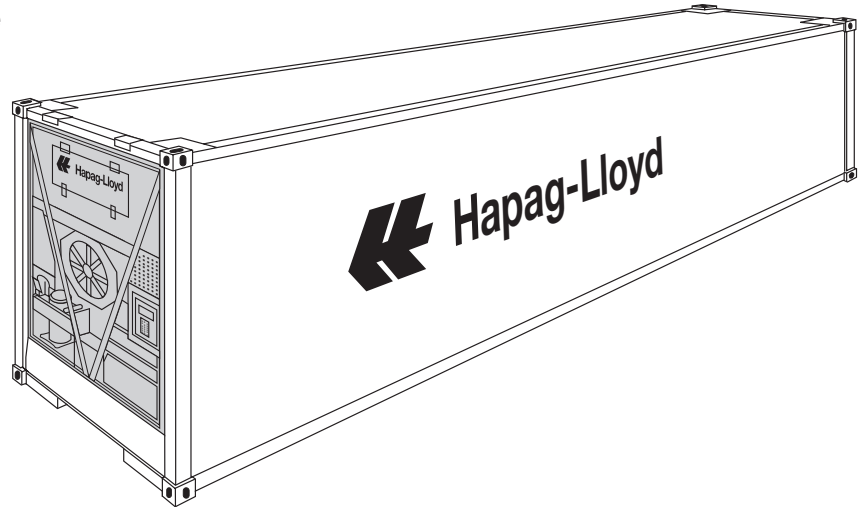

- State of the art insulation factors.
- Container available for set points as low as -35° C.
- De-humidification option available.
- Cold treatment available (USDA).
- Controlled fresh-air supply with up to 280 qm/h.
- ATO-DLO certification for flowerbulk.
- Integrated datalogger storing temperatures and events hourly.
- Low power consumption.
- Only use of environmental friendly refrigerants.
- Dedicated equipment for chemical/ non-foodstuff cargoes.
- Other series solely for foodstuff cargoes.
- The Container is designed to maintain the set point temperature.
- The cargo shall be pre-cooled to match all required in transit temperature.
- Especially for cargo which needs constant temperatures above or below freezing point.
- Suitable for Clip-on generator.
- AFAM on request available.
- Please note maximum stowage height in below table and as indicated by red line inside the container in order to ensure proper air circulation.
- Voltages 380 V/50 Hz to 460 V/60 Hz
- Technical specification and illustration of electric plugs see page 44.
- Freshair recording available

High Cube Refrigerated Container

40'

Containers are available for set points as low as **-35° C and up to +30° C**, please contact your local Hapag-Lloyd office for availability.

Construction	Inside Dimensions				Door Opening		Weights			Capacity m ³ cu.ft	Hapag-Lloyd Serial Number	Foot- note
	Length	Width	Height	Max. stow. Height	Width	Height	Max. Gross	Tare	Max. Payload			
	mm ft	mm ft	mm ft	mm ft	mm ft	mm ft	kg lbs	kg lbs	kg lbs			
8'6" high non foodstuff												
Steelframe, Sandwich walls	11 563 37'11 ¹ / ₄ "	2 294 7'6 ¹ / ₄ "	2 261 7'5"	2 161 7'1"	2 288 7'6"	2 188 7'2 ¹ / ₈ "	30 480 67 200	4 600 10 140	29 400 64 820	60,0 2120	HXLXU 770 000 – 770 149	
9'6" high												
Steelframe, Sandwich walls	11 643 38'2"	2 288 7'6 ¹ / ₈ "	2 498 8'2 ³ / ₄ "	2 378 7'9 ⁵ / ₈ "	2 288 7'6 ¹ / ₈ "	2 517 8'3 ¹ / ₈ "	30 480 67 200	4 180 9 220	26 300 57 980	66,5 2348	HLCU 475 000 – 475 299	
	11 575 37'11 ⁵ / ₈ "	2 294 7'6 ¹ / ₄ "	2 560 8'4 ³ / ₄ "	2 440 8'	2 286 7'6"	2 570 8'5 ¹ / ₈ "	32 500 71 650	4 300 9 480	28 200 62 170	68,0 2400	HLCU 476 000 – 476 499 HLCU 477 200 – 477 499	1) 2) 1)
	11 568 37'11 ³ / ₈ "	2 290 7'6 ¹ / ₈ "	2 509 8'2 ³ / ₄ "	2 389 7'10"	2 290 7'6 ¹ / ₈ "	2 473 8'1 ³ / ₈ "	32 480 71 600	4 240 9 350	28 240 62 250	66,4 2345	HLCU 477 000 – 477 199	
	11 580 37'11 ⁷ / ₈ "	2 288 7'6 ¹ / ₈ "	2 498 8'2 ³ / ₈ "	2 378 7'9 ⁵ / ₈ "	2 288 7'6 ¹ / ₈ "	2 517 8'3 ¹ / ₈ "	30 480 67 200	4 180 9 220	26 300 57 980	66,2 2370	HLCU 477 500 – 477 999 HLCU 478 700 – 478 799	
	11 580 37'11 ⁷ / ₈ "	2 290 7'6 ¹ / ₈ "	2 513 8'3"	2 393 7'10 ¹ / ₄ "	2 290 7'6 ¹ / ₈ "	2 522 8'3 ¹ / ₄ "	30 480 67 200	4 180 9 220	26 300 57 980	67,0 2370	HLCU 478 000 – 478 399	
	11 580 37'11 ⁷ / ₈ "	2 286 7'6"	2 528 8'3 ¹ / ₂ "	2 408 7'10 ³ / ₄ "	2 286 7'6"	2 545 8'4 ¹ / ₈ "	30 480 67 200	4 000 8 820	26 480 58 380	67,0 2366	HLCU 478 400 – 478 599	
	11 580 37'11 ⁷ / ₈ "	2 286 7'6"	2 515 8'3"	2 395 7'10 ¹ / ₄ "	2 286 7'6"	2 535 8'3 ³ / ₄ "	30 480 67 200	4 150 9 150	26 330 58 050	67,0 2366	HLCU 478 600 – 478 699	

Remarks:

- 1) On request upgraded to max payload 34 000 kg available.
- 2) Prepared for being equipped with additional cargo temperature sensors (USDA).

High Cube Refrigerated Container

40'

Containers are available for set points as low as **-35° C** and up to **+30° C**, please contact your local Hapag-Lloyd office for availability.

Construction	Inside Dimensions				Door Opening		Weights			Capacity m ³ cu.ft	Hapag-Lloyd Serial Number	Foot- note
	Length	Width	Height	Max. stow. Height	Width	Height	Max. Gross	Tare	Max. Payload			
	mm ft	mm ft	mm ft	mm ft	mm ft	mm ft	kg lbs	kg lbs	kg lbs			
9'6" high												
Steelframe, Sandwich walls	11 578 37'11 ³ / ₄ "	2 295 7'6 ³ / ₈ "	2 550 8'4 ³ / ₈ "	2 425 7'11 ¹ / ₂ "	2 290 7'6 ¹ / ₈ "	2 560 8'4 ³ / ₄ "	30 480 67 200	4 640 10 230	25 840 56 970	67,8 2 394	HLXU 475 000 – 475 299 HLXU 476 000 – 476 649	2) 2)
	11 585 38'	2 290 7'6 ¹ / ₈ "	2 525 8'3 ³ / ₈ "	2 405 7'10 ⁵ / ₈ "	2 290 7'6 ¹ / ₈ "	2 490 8'2"	34 000 74 950	4 190 9 240	29 810 65 710	67,0 2 366	HLXU 475 300 – 475 749	
	11 577 37'11 ³ / ₄ "	2 286 7'6"	2 525 8'3 ³ / ₈ "	2 400 7'10 ¹ / ₂ "	2 286 7'6"	2 490 8'2"	34 000 74 950	4 110 9 060	28 890 65 900	66,8 2 366	HLXU 476 650 – 477 999	
	11 577 37'11 ³ / ₄ "	2 286 7'6"	2 532 8'3 ⁵ / ₈ "	2 407 7'10 ³ / ₄ "	2 294 7'6 ¹ / ₄ "	2 550 8'4 ³ / ₈ "	34 000 74 950	4 190 9 240	29 810 65 710	67,0 2 366	HLXU 475 750 – 475 984 HLXU 478 000 – 478 599	
	11 583 38'	2 286 7'6"	2 532 8'3 ⁵ / ₈ "	2 412 7'11"	2 294 7'6 ¹ / ₄ "	2 550 8'4 ³ / ₈ "	34 000 74 950	4 120 9 080	29 880 65 870	67,0 2 366	HLXU 478 600 – 478 999	
	11 595 38'1 ¹ / ₂ "	2 296 7'6 ³ / ₈ "	2 542 8'4"	2 402 7'10 ¹ / ₂ "	2 294 7'6 ¹ / ₄ "	2 550 8'4 ³ / ₈ "	34 000 74 950	4 190 9 230	29 810 65 720	67,7 2 390	HLXU 670 000 – 670 399	
	11 595 38'1 ¹ / ₂ "	2 296 7'6 ³ / ₈ "	2 542 8'4"	2 402 7'10 ¹ / ₂ "	2 294 7'6 ¹ / ₄ "	2 550 8'4 ³ / ₈ "	34 000 74 950	4 150 9 150	29 850 65 609	66,8 2 359	HLXU 670 400 – 672 899	3)
	11 578 37'11 ³ / ₄ "	2 280 7'5 ³ / ₄ "	2 525 8'3 ³ / ₈ "	2 400 7'10 ¹ / ₂ "	2 276 7'5 ³ / ₈ "	2 471 8'1 ¹ / ₄ "	34 000 74 960	4 240 9 348	29 760 65 609	66,8 2 359	HLXU 672 900 – 673 399	3)

Remarks:

Prepared for being equipped with additional cargo temperature sensors (USDA).

- 2) On request upgraded to max payload 32 800 kg available.
- 3) De-humidification option installed.

High Cube Refrigerated Container

40'

Containers are available for set points as low as **-35° C** and up to **+30° C**, please contact your local Hapag-Lloyd office for availability.

Construction	Inside Dimensions				Door Opening		Weights			Capacity m ³ cu.ft
	Length	Width	Height	Max. stow. Height	Width	Height	Max. Gross	Tare	Max. Payload	
	mm ft	mm ft	mm ft	mm ft	mm ft	mm ft	kg lbs	kg lbs	kg lbs	

Hapag-Lloyd Serial Number	Foot- note
---------------------------------	---------------

9'6" high

Steelframe, Sandwich walls	11 578 37'11 ³ / ₄ "	2 280 7'6 ³ / ₈ "	2 525 8'4 ³ / ₈ "	2 405 7'10 ⁵ / ₈ "	2 290 7'6 ¹ / ₈ "	2 530 8'4 ³ / ₄ "	34 000 74 960	4 200 9 260	29 800 65 697	66,8 2 359
	11 585 38'1 ¹ / ₈ "	2 290 7'6 ¹ / ₈ "	2 525 8'3 ³ / ₈ "	2 405 7'10 ⁵ / ₈ "	2 290 7'6 ¹ / ₈ "	2 490 8'2"	34 000 74 960	4 190 9 240	29 810 65 710	67,0 2 366
	11 577 37'11 ⁷ / ₈ "	2 286 7'6"	2 525 8(3 ³ / ₈)"	2 405 7'10 ⁵ / ₈ "	2 286 7'6"	2 490 8'2"	34 000 74 960	4 110 9 060	28 890 65 900	66,8 2 66
	11 580 37'11 ⁷ / ₈ "	2 290 7'6 ¹ / ₈ "	2 543 8'4 ¹ / ₈ "	2 423 7'11 ³ / ₈ "	2 294 7'6 ¹ / ₄ "	2 550 8'4 ³ / ₈ "	34 000 74 950	4 550 10 031	29 450 64 925	67,44 2 381
	11 580 37'11 ⁷ / ₈ "	2 290 7'6 ¹ / ₈ "	2 540 8'4"	2 420 7'11 ¹ / ₄ "	2 290 7'6 ¹ / ₄ "	2 569 8'4 ³ / ₈ "	34 000 74 960	4 430 9 770	29 570 65 170	67,36 2 380
	11 578 37'11 ³ / ₄ "	2 280 7'6 ³ / ₈ "	2 525 8'3 ³ / ₈ "	2 405 7'10 ⁵ / ₈ "	2 276 7'5 ⁵ / ₈ "	2 535 8'3 ³ / ₄ "	34 000 74 960	4 300 9 480	29 700 65 477	66,7 2 356
	11 580 37'11 ⁷ / ₈ "	2 290 7'6 ¹ / ₈ "	2 540 8'4"	2 420 7'11 ¹ / ₄ "	2 290 7'5 ⁵ / ₈ "	2 569 8'1 ¹ / ₄ "	34 000 74 960	4 460 9 833	29 540 65 609	67,36 2 359

HLXU 673 400 – 673 649	3)
HLXU 673 650 – 674 549	3)
HLXU 674 550 – 674 699	3)
HLXU 674 700 – 675 199	3)
HLXU 675 200 – 676 099	3)
HLXU 676 100 – 676 599	3)
HLXU 676 600 – 678 499	3)

Remarks:

Prepared for being equipped with additional cargo temperature sensors (USDA).

3) De-humidification option installed.

Tank Container

20'

ISO Size Type Codes: 20 T5 = 8' high
22 T0 = 8'6" high (22 T5 / 22 T6)

- Hapag-Lloyd provides tank containers which are approved to the highest standards. Depending on the characteristics of the products to be carried the requirements vary. Hapag-Lloyd offer their services on operational, technical and regulatory questions.
- Separate tank fleets are available for:
FOODSTUFFS, e.g.:
 - Alcohols
 - Fruit juices
 - Edible oils
 - Food additivesCHEMICAL PRODUCTS, e.g.:
 - Flammables
 - Oxidising agents
 - Toxic substances
 - Corrosives
- Tanks must be filled to not less than 80 % of their capacity to avoid dangerous surge/swell during transport.

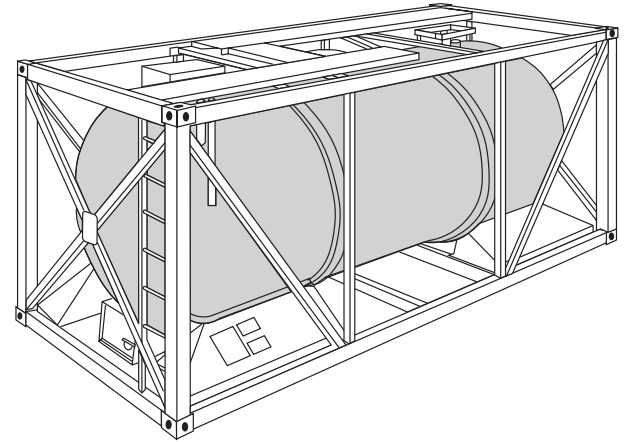

- Tanks must not be filled to 100% of their capacity. Sufficient ullage space shall be left – which must be determined depending on the thermal expansion of the product to be carried.
- Certain dangerous products must be carried in tanks having no openings below the surface level of the liquid. Such tanks must be discharged through a syphon pipe by either pressure or pumping.
- National road/rail weight limitations have to be maintained when arranging land transports.
- For the cleaning of tanks and disposal of residues tariff rules apply. Tanks moving in a dedicated service are exempted from such rules until the dedication is terminated.
- **For more details please contact your nearest Hapag-Lloyd office or agent and let our experience work for you.**

Electric Plugs on Refrigerated Containers

- Depending on power sources refrigerated containers are equipped with 1 or 2 plugs
380 V/50 Hz to 460 V/60 Hz (32 A).
200 V/50 Hz to 220 V/60 Hz (60 A).
- There are fixed cables with a length of 15 m (49 ft).
- Couplings for adapters are available.
- **Adapters are subject to corresponding safety regulations.**

380/460 V plugs:

- 4poles according to CEE.
- According to ISO 1496-2 annex M.
- **Earth contact in 3hr position according to socket.**

Earth Contact

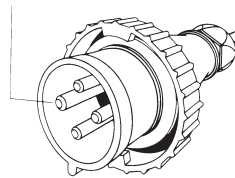

all series

200/220 V plugs:

- 4poles.
- According to ISO 1496-2 annex O.
- **Position of earth contact according to illustration.**

Earth Contact

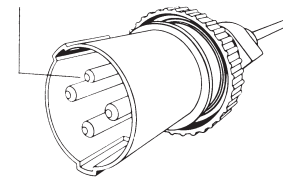

some series

Essential Conversion Factors

MULTIPLY NUMBER OF	BY	TO OBTAIN EQUIVALENT NUMBER OF
Inches/in/)	25.4	Millimetres/mm
Feet/ft/(0.3048	Metres/m
Millimetres/mm	0.0394	Inches/in/)
Metres/m	3.281	Feet/ft/(
Sq. Metres/m	10.7639	Sq. Feet/ft
Sq. Feet/ft	0.0929	Sq. Metres/m
Cu. Feet/ft	0.0283	Cu. Metres/m
Cu. Metres/m	35.315	Cu. Feet/ft
Litres	0.0353	Cu. Feet/ft
Cu. Feet/ft	28.317	Litres
Litres	0.2642	U.S. Gallons
U.S. Gallons	3.785	Litres
Litres	0.22	U.K. Gallons
U.K. Gallons	4.5461	Litres
U.K. Gallons	1.2001	U.S. Gallons
U.S. Gallons	0.8327	U.K. Gallons
Kilograms/kg	2.2046	Pounds/lb
Pounds/lb	0.4536	Kilograms/kg
Long Tons (2240 lb)	1.01605	Tonnes (2204.62 lb)
Tonnes (1000 Kg)	0.9842	Long Tons (1016.05 Kg)
Bar	14.504	PSI
PSI	0.06895	Bar
Inches HG	0.4912	PSI
PSI	2.036	Inches HG
Kg/sq. cm	14.223	PSI
PSI	0.0703	Kg/sq. cm
Kg/sq. cm	0.9807	Bar
Bar	1.02	Kg/sq. cm
Kg/sq. cm	28.976	Inches HG
Inches HG	0.0345	Kg sq. cm
Degrees Fahrenheit	5/9, after subtracting 32	Degrees Celsius (Celtigrade)
Degres Celsius (Centigrade)	9/5, and add 32	Degrees Fahrenheit

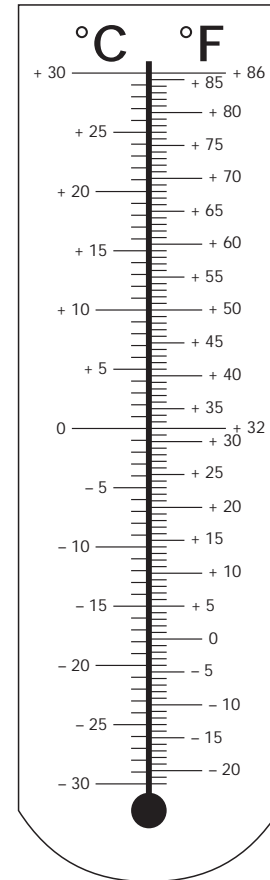

Container Size Type Codes according to ISO 6346

Hapag-Lloyd owned and longterm leased container types

Size (LxH)	Type	ISO Type Group	ISO Size Type	ISO Type Group di*	ISO Size Type di*
		1	2	1a	2a
20 x8"	General Purpose	20GP	20G0		
20 x8'6"	General Purpose	22GP	22G0		
		22GP	22G1		
20 x8 6"	General Purpose (Fantainer)	22VH	22V2		
		22VH	22V3*		22V2
20 x8 6"	Ventilated	22VH	22V0		
20 x8 6"	Bulk	22BU	22B0		
20 x8 6"	Open Top	22UT	22U1		
20 x8 6"	Hardtop	22UP*	22U6*	22UT	22U1
20 x1 1 ¹ / ₄ "	Platform	29PL	29P0		
20 x8'	Flat (fixed ends)	20PF	21P1		
20 x8 6"	Flat (fixed ends)	22PF	22P1		
20 x8 6"	Flat (collapsible)	22PC	22P3		
20 x8 6"	Flat (coll., flush folding)	22PC	22P8*		22P3
20 x8 6"	Refrigerated	22RT	22R1		
20 x8 6"	Refrigerated (no foodstuffs)	22RC*	22R9*	22RT	22R1
20 x8'	Insulated	20HR	20H0		
20 x8 6"	Tank (non-dangerous liquids)	22TN	22T0		
40 x8 6"	General Purpose	42GP	42G0		
		42GP	42G1		
40 x9 6"	High Cube GP	45GP	45G0		
		45GP	45G1		
40 x8 6"	Open Top	42UT	42U1		
40 x8 6"	Hardtop	42UP*	42U6*	42UT	42U1
40 x9 6"	High Cube Hardtop	45UP*	45U6*	45UT	45U1
40 x2'	Platform	49PL	49P0		
40 x8 6"	Flat (fixed ends)	42PF	42P1		
40 x8 6"	Flat (collapsible)	42PC	42P3		
40 x8 6"	Flat (coll., flush folding)	42PC	42P8*		42P3
40 x9 6"	Flat (collapsible)	45PC	45P3		
40 x9 6"	Flat (coll., flush folding)	45PC	45P8*		45P3
40 x8 6"	Refrigerated	42RT	42R1		
40 x8 6"	Refrigerated (diesel genset)	42RS	42R3		
40 x8 6"	Refrigerated (no foodstuffs)	42RC*	42R9*	42RS	42R3
40 x9 6"	Refrigerated	45RT	45R1		
40 x9 6"	Refrigerated (no foodstuffs)	45RC*	45R9*	45RT	45R1
40 x8 6"	Insulated	42HR	42H0		
45'x9'6"	High Cube Cont.	L5GP	L5G1		

*) Some Types/Groups in columns "1" and "2" are marked as non-ISO.

"*" means ISO spares codes have been used.

If official ISO codes are required for data interchange (di)

pls use entries in columns "1a" and "2a".

